

**38" SNOWBLOWER WITH 812 GRAVELY
EQUIPPED WITH HYDRAULIC LIFT**

GENERAL

1. The 38" Snowblower is a front-mounted unit designed and built to give many years of excellent service. The tractor/snowblower combination has all gear drive from the engine to the snow and is recommended for both homeowner and commercial snow removal, has heavy-duty housings, drive, fan, reel, and controlled direction of discharge.
2. The Owners Manual includes set up, safety, operator and maintenance instructions. Item numbers used in this manual are in reference to the Illustrated Parts List, fig 1. Contact The Gravelly Dealer for further information.
3. To continue its program of quality and design improvement, the manufacturer reserves the right to change specifications, design or prices without incurring obligation.

Special Use Accessories
Wheel Brakes
Weight Rack

4. SPECIFICATIONS

Path Width: 38 inches
Extends tractor length: 33 inches
Weight: 250 pounds
Drive: steel shafts, universal joints, ball and needle bearings, cast iron housings, overload reel clutch
Construction: heavy gage steel tubing and stamping weldments
Features: 2 stage operation (reel and fan), directional discharge controlled from operators position, replaceable wearstrip and skids
Purpose: general snow removal

Recommended for Single Cylinder Riding Gravelys 10 hp and greater. Requires Front Drive Kit.

Recommended Accessories

Tire Chains
Wheel Weights
Lift Assist and
Lift Assist Auxilliary Kits
(For Manual Lift)

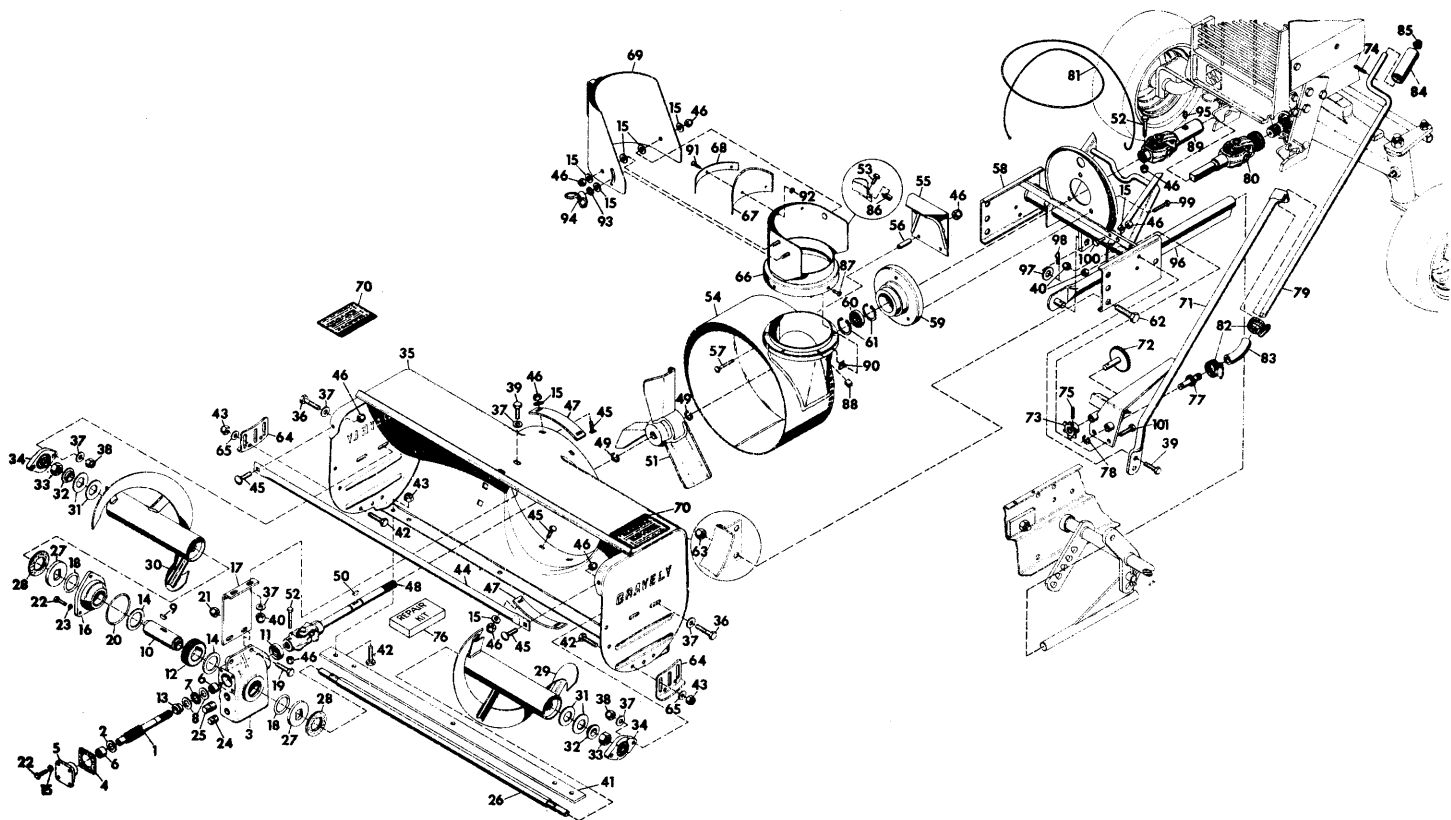

ITEM NO.	PART NO.	DESCRIPTION	ITEM NO.	PART NO.	DESCRIPTION
1	20696P1	Shaft, SnowBlower Worm	50	124553	Key, Woodruff 1/4 x 1 Hard No. 15
2	9659P1	Washer, Thrust	51	19731A1	Fan Weldment
3	10573P1	Housing, SnowBlower Gear	52	180044	Bolt, Hex 1/4-20 x 2
4	6339P1	Gasket, Bearing Cap	53	180016	Bolt, Hex 1/4-20 x 1/2
5	6341P1	Cap, Front Pinion Bearing	54	6410A1	Fan Housing Weldment
6	9660P1	Bearing, Torrington B-128	55	6370A1	Guide, Cable Weldment
7	9661P1	Bearing, Torrington #NTC-1427	56	6375P1	Spacer, 3/8 x 5/8 x 1-7/16
8	9662P1	Bearing, Needle Thrust Race	57	126344	Bolt, 1/4-20 x 2 Rd. Hd. Sq. Nk.
9	12403P1	Key	58	19733A1	Support Weldment
10	12402P1	Tube, Reel Gear	59	19740P1	Support
11	9667P1	Seal, Oil Garlock 94 x 6120	60	19741P1	Bearing, Ball 1.000 x 2.000 x .500
12	12401P1	Gear, Worm	61	20859P1	Ring, Bearing
13	10325P1	Spacer	62	180175	Bolt, Hex 1/2-13 x 1-1/4
14	12404P1	Bearing, Thrust Race Torr Trd-2840	63	435507	Nut, Lock 1/2-13 Washer Insert Hex
15	120392	Washer, Flat 9/32 x 5/8 x .065	64	17261P1	Shoe-Skid
16	12400P1	Cap, Gear Housing	65	446354	Washer Flat 5/16 x 7/8 x .065
17	10579P1	Bracket, Gear Box Support	66	6404A1	Chute, Weldment
18	9668P1	O-Ring, 1-3/4 x 2-1/8 x 3/16	67	6352P1	Baffle, Deflector
19	181666	Bolt, Hex 7/16-20 x 1	68	10496P1	Retainer, Baffle
20	9669P1	O-Ring, 3 x 3-1/4 x 1/8	69	6399A1	Chute, Deflector Weldment
21	274655	Nut, Lock 7/16-20 Type N Hex	70	19479P1	Decal, Caution
22	180020	Bolt, Hex 1/4-20 x 3/4	71	19744A1	Support Weldment
23	120423	Washer, Lock 1/4 Int. Tooth	72	19749A1	Gear Weldment
24	103880	Plug, Pipe 1/2 In. Sq. Hd. Steel	73	19753P1	Sprocket, SnowBlower
25	103879	Plug, Pipe 3/8 In. Sq. Hd. Steel	74	454563	Pin, Spring 3/16 x 7/8 CAD
26	11796P1	Shaft, Reel	75	412281	Pin, Spring 1/4 x 1
27	12399P1	Plate, Drive	76	12134P1	Kit, Repair Universal Joint Rockwell Std.
28	9657P1	Disc, Friction	77	20573P1	Kit, Repair Universal Joint Neapco 1605X
29	11802A1	Reel, Weldment L.H.	78	19754A1	Gear Weldment
30	11797A1	Reel, Weldment R.H.	78	14981P1	E-Ring, No. 5133-50 TRUARC
31	6493P1	Washer, Belleville Spring 1-1/4 x 2-1/2	79	11805P1	Crank
32	6494P1	Washer, Pilot	80	20727P1	Joint, U Male End
33	426767	Nut, Hex 7/8-14	81	6381P1	Rope, Wire
34	12409P1	Bearing, Flange	82	9630P1	Clamp, Hose SAE Type F
35	20726A1	Body Weldment, 38" SnowBlower	83	9612P1	Connector
36	180080	Bolt Hex 5/16-18 x 1-1/8	84	10211P1	Grip, Handle
37	120394	Washer, Flat 13/32 x 13/16 x .065	85	10210P1	Cap, Stud
38	9419455	Nut, Lock 5/16-18 Washer Insert Hex	86	6496P1	Clamp
39	180122	Bolt, Hex 3/8-16 x 1	87	159582	Screw, Mach 8-32 x 3/8 Pan Hd.
40	456004	Nut, Lock 3/8-16 Washer Insert Hex	88	10580P1	Glide
41	11788P1	Strip, Wear	89	20728P1	Joint, U Female End
42	180075	Bolt, Hex 5/16-18 x 5/8	90	445339	Nut, Spring Shape 8032 Type A-J
43	9413447	Nut, Lock 5/16-18 Type N Hex	91	155886	Screw, Mach 8-32 x 1/2 Flat Hd. Cross Recess
44	11789P1	Guard	92	120622	Nut, Mach. 8-32 Hex
45	120518	Bolt 1/4-20 x 3/4 Rd. Hd. Sq. Nk.	93	120380	Washer, Lock 1/4 SP
46	9419454	Nut, Lock 1/4-20 Washer Insert Hex	94	6464P1	Nut, Deflector Wing
47	6477P2	Ring, Bearing	95	9411027	Fitting, Lube 1/4-28
48	19728A1	Drive Shaft Weldment	96	11809A1	Rod, Push Weldment
49	14987P1	Ring, Retaining Eaton 329-1	97	131017	Washer, Flat 13/6 x 1-15/32 x .134
			98	10405P1	Pin, Hair Cotter
			99	180021	Bolt, Hex 1/4-20 x 7/8
			100	180024	Bolt, Hex 1/4-20 x 1-1/4
			101	180123	Bolt, Hex 3/8-16 x 1-1/8

fig 1 ILLUSTRATED PARTS LIST

ASSEMBLY

BUILDING UP THE CHUTE

1. Slide 4 plastic glides into slots on fan housing flange, Item 88. Put a heavy coat of general purpose grease on top and bottom of each glide.
2. Slide 4 spring nuts into position over holes on chute ring, Item 90.
3. Set chute on flange, Item 66. Bring ring up into chute. Fasten together with screws, Item 87.
4. Fasten rubber baffle onto chute with retainer strap, nuts and bolts, Items 67, 68, 91 and 92.
5. Dab inside of deflector (about the holes and slot) with general purpose grease, Item 69.
6. Slide a washer on each mounting stud of chute, Item 15; do not use a washer on adjusting stud that goes in slot.
7. Put deflector on chute and fasten it with washers and locknuts, Items 15, 46 and 69. Tighten nuts enough to be secure and then back off until deflector can be pivoted.
8. Put a flatwasher, lockwasher, and wingnut on the adjusting stud, Item 15, 93 and 94. Make the wingnut finger tight. Deflector position is not important at this time, fig 2.

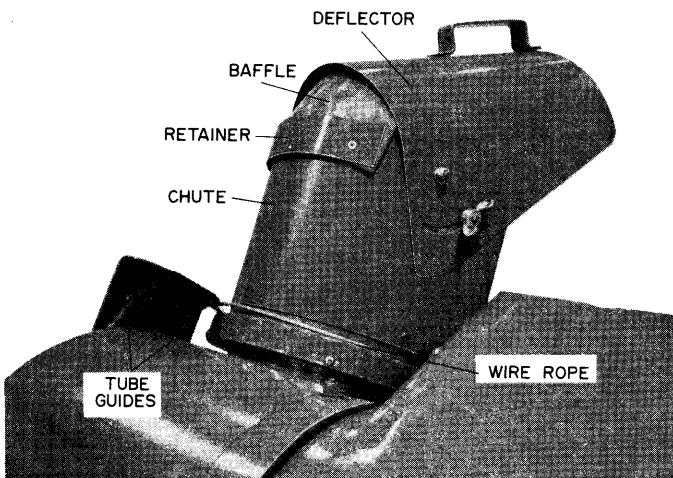

fig 2

WIRE ROPE ROUTING

9. Start wire rope through hole in bottom right side of round cable guide, Item 81.
10. Thread wire rope up through tube of cable guide, Item 55. Wrap it around chute. Note: be sure that cable is under bracket that is welded to side of chute.
11. Slide wire rope down through other tube on cable guide. Do not be concerned with chute direction at this time.
12. Run wire rope down round cable guide and through cable hole. Take slack out of wire rope.
13. Put bolt, Item 100, through hole in frame and wrap cable around it one time. Fasten together with washer and nut, Items 15 and 46.
14. Hand adjust fan housing to maximum left position; discharge chute will rest on frame. Turn chute/deflector assembly so it points to exact left.
15. Slide clamp into position under bracket and on top of wire rope. Tighten bolt against clamp, Items 53 and 86, fig 3.

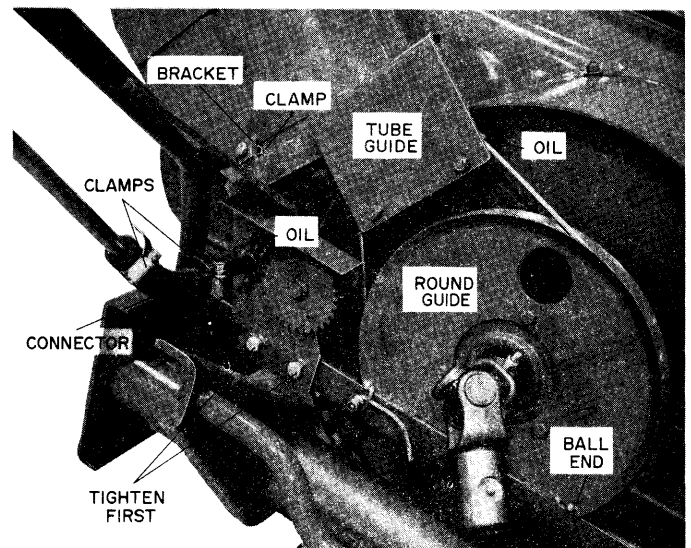

fig 3

FINAL ASSEMBLY

16. Bolt crank support assembly to frame, Items 58 and 71. Be sure gear meshes with fan housing, Items 54 and 73. Tighten bolts under gears first and then tighten crank support bolts, fig 3.

17. Assembly handle to crank, Items 74, 79, 84 and 85. When installing pin, Item 74, have same length of pin extending on both sides of crank. Slide on handle and secure by driving on self-gripping cap.
18. Push connector about one inch onto gear shaft, Items 77 and 83. Put both clamps loosely on connector, Item 82.
19. Put crank down through support and about one inch into connector. Tighten clamps over shafts. Tighten clamps until connector starts to come through slots in clamp. Tighten clamp on gear shaft over serrations for maximum holding power.
20. Bolt skids onto reel housing, Items 42, 43, 64 and 65.
21. Bolt "U" joint of drive shaft to fan shaft, Items 46, 48, 52 and 89. Coat rectangular male shaft with general purpose grease and slide it into female shaft, Items 80 and 89.
22. Connect push rod to frame, Items 58, 96, 97 and 98.

LUBRICATION

23. Lubricate drive shaft through grease fitting with general purpose grease, Items 80, 89 and 95. Add grease until it comes out about rectangular shaft. Remove excess grease.
24. Oil wire rope where it goes through tube guides, Item 35.
25. Oil gear shafts, Items 72 and 77.

TESTING

26. Remove gear box check plug, Items 3 and 25. Add SAE 90W EP gear lubricant (if necessary) to bring level up to plug. Replace plug.
27. Turn drive shaft by hand. Reel and fan should turn free and smooth.
28. Turn Crank. Discharge port of fan housing should move from side to top to side and as this happens discharge chute should rotate on port flange and point from side to front to side.

SAFETY PRECAUTIONS

1. READ THE GRAVELLY OWNERS MANUAL. Be familiar with all controls and follow the safety precautions outlined in the manual. Know how to STOP quickly in an emergency.

2. INSPECT AND CLEAR the work area (prior to snow fall) of rocks, glass, metal, bones, and any other foreign objects that might be picked up and thrown. Stay alert for holes and o' hidden hazards.
3. DO NOT WEAR loose fitting clothing or accessories that might get caught in moving parts or on the controls. Keep hands, feet, hair, clothing, etc., away from moving parts.
4. KEEP BYSTANDERS and pets removed from the work area, and a safe distance away.
5. DO NOT ALLOW CHILDREN to operate the equipment, NOR ALLOW ADULTS to operate it without their having knowledge of safe operating practices.
6. OPERATE THE EQUIPMENT from the proper operator's position on the seat.
7. KEEP SAFETY devices, interlocks and shields in place at all times.
8. PUT THE PTO in the OUT position when the snowblower is not in use or is being transported.
9. ADJUST HEIGHT to clear gravel or crust rock surfaces. Disengage PTO and STOP engine BEFORE making this adjustment.
10. DIRECT DISCHARGE so as not to endanger life or property such as people, pets, structures, cars, etc.
11. DISENGAGE POWER to the snowblower and STOP the engine BEFORE clearing the unit.
12. PUT THE PTO in the OUT position BEFORE adjusting the discharge chute deflector.
13. AFTER STRIKING a foreign object, STOP the engine and put the PTO in the OUT position BEFORE inspecting for damage. Any damage must be repaired before restarting the equipment.
14. NEVER LEAVE the equipment running when unattended - always STOP engine, lower snowblower, remove key, set parking brake, and put the PTO in the OUT position when leaving the machine.
15. NEVER OPERATE the snowblower in darkness. Use good artificial light when operating at night.
16. MAINTAIN THE EQUIPMENT in safe operating condition. Keep the machine in good maintenance and all fasteners secure.

CONNECTING TO THE GRAVELY

1. STOP engine, disengage PTO and put direction control in NEUTRAL.
2. Install Front Drive Kit on The Gravelly. Coat PTO shaft of transaxle and PTO of front axle with general purpose grease.
3. Remove hairpin cotters and open equipment latches on front of The Gravelly.
4. Guide The Gravelly up to snowblower. Join support weldment crossbar to latches. Close latches and secure with hairpin cotters.
5. Connect drive shaft collar to PTO shaft. Be sure collar "clicks" and locks in position.
 - A. Twist Type collar: Rotate collar ring (in direction of arrow on ring) and hold. Slide collar half way on shaft. Release ring and continue sliding on shaft until collar "clicks" and locks in position.
 - B. Slide Type collar: Slide collar ring towards "U" joint and hold. Slide collar half way on shaft. Release ring and continue sliding on shaft until collar "clicks" and locks in position.
6. Slide male pushrod of Front Drive Kit into female pushrod of snowblower, Item 96. Connect male pushrod to lift weldment as shown in fig 1.
4. Periodically check all fasteners for tightness. Maintain snowblower in safe operating condition.
5. Periodic oiling of the tube guide and gear shafts, Items 55, 72, & 77, and areas where the fan housing meets the reel housing will aid operation.

ADJUSTMENTS

1. DISCHARGE DIRECTION CONTROL: Turn the crank to direct blown snow left, forward or right. Since this adjustment is made from the operators position, it can be done any time during normal operation of the unit.
2. CHUTE DEFLECTOR: Used in conjunction with the discharge chute. Because the operator must leave the operator's position to adjust it. STOP The Gravelly and put the PTO in the OUT position before adjusting the deflector. Normally, the deflector is used to limit the distance the snow is blown. Procedure: Loosen wing nut, adjust deflector, tighten wing nut finger tight.
3. GROUND CLEARANCE: Adjusted by the positioning of the skids on the sides of the reel housing, Item 64. Generally, the snowblower can be fully lowered when removing snow from pavement. When using snowblower on crushed rock or gravel surfaces, adjust the skids so the snowblower will not pick up and throw stones.

Procedure:

 - A. Raise the snowblower to the transport position allowing the skids to be above the ground.
 - B. STOP engine, disengage PTO.
 - C. Loosen nuts and bolts fastening skids to reel housing.
 - D. Adjust each skid the same amount.
 - E. Tighten fasteners and remove from support.
4. REEL OVERLOAD CLUTCH: To be adjusted when reel stalls under moderate load while fan still turns.

Procedure:

 - A. STOP engine, disengage PTO.
 - B. Block fan with piece of wood or facsimile to keep it from turning when adjusting reel clutch.
 - C. Tighten reel nut, Item 33, to approximately 85 ft. lbs. of torque. Similar tightness can be reached with an 18" handle wrench when used by an average man.
 - D. Remove "block" from fan.

ROUTINE MAINTENANCE

1. Check oil level in gearbox before first use and then once a season, Item 3. Check more often if signs of leakage are present. Visually inspect for leaks before each use. A repair should be made if leakage is substantial. Level must be up to check plug, Item 25, use SAE 90W EP gear oil.

Procedure for checking oil level

 - A. Have snowblower level.
 - B. Unscrew top plug, Item 25.
 - C. Add gear oil (if necessary) to bring level up to hole.
 - D. Replace plug.
2. Adjust reel overload clutch as necessary, see ADJUSTMENTS.
3. After each use inspect reel, fan, skids and wearstrip for wear or damage. Repair or replace as necessary.

OPERATION

1. Read The Gravelly Owners Manual. Know how to operate and stop the tractor quickly in an emergency.
2. Before starting the engine adjust the skids for adequate ground clearance.
 - A. On smooth, paved surfaces the snowblower may be lowered to where the wearstrip is flush with the pavement.
 - B. On loose or gravel surfaces, adjust the snowblower high enough to clear the gravel so it will not pick up and throw stones.See ADJUSTMENTS section for procedure.
3. Lower snowblower to the "float" position. Adjust discharge chute and deflector to desired position: see ADJUSTMENTS section for procedure.
4. Start engine; allow it to warm up a few minutes.
5. To begin, select The Gravelys slowest ground speed. Engage PTO, move throttle to FULL THROTTLE and start forward.
6. Generally, on the first pass, a full width swath must be made.
 - A. In snow that is deep and/or wet (most difficult for the snowblower to handle) stop forward motion as necessary until the unit clears itself. Keep the engine at full throttle.
 - B. In light snow that moves freely (dry and not very deep), change to a higher gear. Keep the engine at full throttle.
7. During the second and remaining passes, take the widest possible cut the snowblower can handle without having to stop and wait for it to clear. Keep the engine at full throttle.
8. Some trials may be necessary to find an optimum ground speed and width of cut. Keep the engine at full throttle.
9. Disengage PTO (OUT position) when transporting.

OPERATING TIPS

1. Clear the work area of foreign objects and debris before snow falls to assure safe operation.

2. Direct discharge over snow yet to be moved to avoid blowing snow on cleared areas.
3. Coating the working surfaces (fan, inside of fan housing and chute, reel and inside of reel housing) with ski wax or facsimile may help prevent snow from sticking.
4. Winterize The Gravelly: Maintain battery at full charge, use proper viscosity oil in engine. Keep fuel tank full to prevent condensation of water vapor inside the tank.
5. Use accessories (listed on cover page) to increase control and safety of operation.
6. Operate the engine at FULL THROTTLE when running the snowblower.

REMOVAL FROM THE GRAVELLY

1. STOP engine, disengage PTO, lower snowblower, and put direction control in NEUTRAL.
2. Disconnect snowblower driveshaft from front axle PTO.
3. Disconnect pushrod lift weldment and remove from snowblower pushrod.
4. Open equipment latches on The Gravelly.
5. Separate The Gravelly from snowblower.
6. Replace hairpin cotters in latches.

STORAGE

1. Check oil level in gearbox, Item 3. Add oil if necessary (see LUBRICATION).
2. Thoroughly dry snowblower.
3. Inspect reel and fan for wear or damage. Replace any worn out parts such as skids or wearstrip.
4. Oil gear shafts, Items 72 & 77.
5. Paint or grease any exposed metal surfaces that might rust.

WARRANTY

Products manufactured by Gravely are warranted to be free from defective material and workmanship for a period of one year from date of purchase, under normal use by a homeowner, and for a period of ninety (90) days from date of purchase, when used for commercial purposes.

Any defective part manufactured by Gravely will be replaced without charge provided such part is certified as defective by the manufacturer or by the manufacturer's expressly authorized representative.

IMPORTANT PROVISIONS

The foregoing warranty is in lieu of all others and GRAVELY MAKES NO REPRESENTATION OR WARRANTY OF ANY KIND, EXPRESS OR IMPLIED, AS TO MERCHANTABILITY, FITNESS FOR PARTICULAR PURPOSE, OR ANY OTHER MATTER.

This warranty is not subject to change or modification by field representatives or Gravely dealers.

Certain components carry separate warranties by the manufacturer of such components. Defective components are subject to their manufacturer's warranties, and any claims, work, or return of parts must be through an authorized Gravely dealer. Service costs for the transporting of a unit to and from the dealer are the responsibilities of the customer, and when such service is performed by the dealer, the dealer will charge the customer the usual rate for such service.

It is the dealer's responsibility to mail the "Warranty Card" to the manufacturer within fourteen (14) days after date of purchase to ensure prompt handling of any warranty claim by the dealer or the manufacturer.



A Division of Clarke-Gravely Corporation

ONE GRAVELY LANE

Clemmons, North Carolina 27012

EFFECTIVE DATE: 11-1-74
FORM NUMBER: 20911L2
PRINTED IN U S A